



waisense comfort



**SPAIN
2020**

1. WHAT IS OUR MOTIVATION?	3
2. WHAT IS WAISENSE COMFORT?	4
Which problems does it solve?	6
3. OPERATION OF WAISENSE COMFORT	7
4. BENEFITS FOR THE USER	9
How much do I save with this technology?	10
5. INSTALLATION OF WAISENSE COMFORT	11
Process description	14
Wall built in plumbing modules	15
Wall surface plumbing modules	16
Activator and Repeater modules	18
Expanding the WAISENSE Comfort	20
Description of the modules	24
6. PRODUCTS CATALOGUE	32
7. FAQs	37

The equipment belonging to WAISENSE Comfort® is adapted to different regions around the world, which are designated in the cover, main index and back cover pages. The reader must understand that the features of the kits and modules, including the price, are adjusted to the current norms and market conditions of the designated region, taking into consideration that these may or may not vary among the geographical areas where WAISENSE Comfort® is available.

If the appointed region is not of your interest, please check the availability of other versions of this dossier for your preferred area. May WAISENSE Comfort® be not specifically adapted for your region of interest, please contact our technical staff for further information. We can advise you about the applicability of the different existing versions of WAISENSE Comfort® to your preferred region.



1. WHAT IS OUR MOTIVATION?

Water is one of the main natural resources for human life, if not the most. One of the greatest challenges of society in this century is to reach a proper and sustainable water usage and management, in order to preserve or improve the current environmental situation of our planet, for ourselves and the generations to come. It is in that context that WAISENSE was born, an international brand that gathers different innovative technologies for water efficiency. Nowadays, there are many individual habits related to daily water consumption that, based on comfort or lack of awareness, seem to be incorrect. **We are frequently powerless witnesses of how many litres of cold water are wasted every time we demand hot water.** At last, new technologies have found a solution that empowers sustainable constructions and installations, generating savings and comfort to the users of these innovations.

WAISENSE, by **WAISENSE Comfort**, is a system that can be installed in any kind of building where hot water is used, turning the facility into a smart and efficient one. The main purpose of WAISENSE Comfort is to carry water from your water heater to the tap where you want to use it, without wasting a single

drop in the process. This innovative device pumps water that has cooled in the hot water pipes after the last usage, guiding it towards the cold water pipes in a recirculation process. Thus, no extra pipes or water tanks are needed, as water is only moving inside the pipes when the taps are all turned off. From now on, you can enjoy hot water, avoiding the previous wastage until it became warm, with the simplicity of a light switch. A simple gesture can provide hot water to every tap in the installation. **This is our little contribution for the next generations to live in a more sustainable world. In fact, it is the contribution of all the users of WAISENSE Comfort.**

WAISENSE Comfort is available in two families of products: Fiji and Jamaica. Both are installed equally, having the same functions. Its only difference comes from the aesthetic design of some of its components.

Do you want to know more? Keep reading and you will find the answer we all have been waiting for.

“Less water wasted means more water for everyone”



POWER MODULE

It is installed before the cold water inlet of your water heater. **This module will pump hot water from that water heater towards the Bypass Module**, inside a room where hot water wants to be used.

BYPASS MODULE

This unit communicates a hot water pipe with a cold water pipe next to a tap, so that the water flows from one to another during the functioning cycle. When the module is not active, this flow is not allowed.

ON-GRID ACTIVATOR MODULE

As you can see, it is very similar to a light switch. **This module is in charge of starting the cycle and warning with a light signal when the hot water is ready at the desired room.**



Besides, **there are two more types of modules**, which are optional. Its introduction to the installation depends on the characteristics of the facility and the user's routines:

2. WHAT IS WAISENSE COMFORT?

The proper technical definition of **WAISENSE Comfort** might be "recirculation system without return pipe", but we prefer to call it "the change in your daily routine you were looking for". If we analyse our house or even our business, we will find many appliances which are not used every day, like: HVAC systems, washing machines, dishwashers, and such. These devices surely make our life easier, but at a cost in energy consumption. **Don't you use hot water more frequently than those appliances? Then, why not simplifying our life with an eco-innovative and efficient water-saving technology?** And what if we tell you that you would not only save water but money? All of this is possible because **WAISENSE Comfort** consumes less energy than water

does save, in economic terms. **Consequently, we can assure that WAISENSE Comfort is the final solution for consuming water more efficiently, introducing the most comfortable evolution in your life.**

WAISENSE Comfort comprises at least three different modules, which intercommunicate wirelessly. Those are: a **Power Module**, a **Bypass Module** and an **Activator Module**. You only need one unit of each to start enjoying what we call smart water living at any site with an individual water heater.

As mentioned earlier, jobs or modifications in your housing or business are optional, as you do not need to add any more pipes or tanks.

On-Battery

Activation Module

It has **the same function as the On-Grid Activator Module** - initiate the hot water and warn with a light change when it is available - but without being connected to the electric network, by using 4 removable batteries as power

HIGH POWER MODULE

It is installed in the same location as the **Power Modules**, having equal purpose but with higher capacities. The **High Power Module** is recommended for installations where higher pressure and flowrate are needed.

REPEATER MODULE

This last component enables the wireless communication when distances between modules are larger than permitted. It can be installed in almost any place of the facility where its function is efficiently executed, as the user does not need to interact with it.



From now on, every time we mention the Activator Module, we will refer to both the On-Grid and On-Battery, since they have the same purpose.

Enjoy



Care



Save



Which problems does it solve?

Usually, when hot water is demanded, the pipe that connects the water heater with a tap is full or cold water (dark-blue pipe in the image below). That cold water is the result of a previous consumption of hot water, where the amount kept in the pipes (that left the water heater but did not reach the tap) has gone cold. This quantity is what everybody frequently waste when they desire hot water: from 6 up to 25 litres (1.3-5.5 gallons) of perfect drinking water in every usage.

The goal of **WAISENSE Comfort** is to bring water from the heater to the place where it is going to be used, pushing cold water in hot water pipes towards cold water pipes through the **Bypass Module** when the cycle is active. This is how a recirculation process is established without adding extra pipes to the installation.

STANDBY STAGE:

Hot water pipes are filled with cold water. At this original state, the **Activator Module** does not show any light signal.

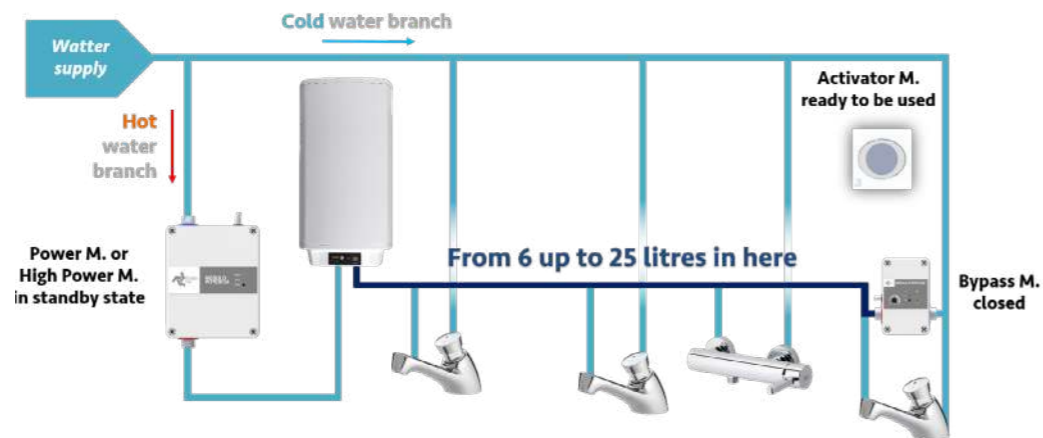

START:

After using the **Activator Module**, the recirculation cycle begins. During this stage, the **Activator Module** shows a blue light, meaning that if we turn the tap on, water will be still cold.

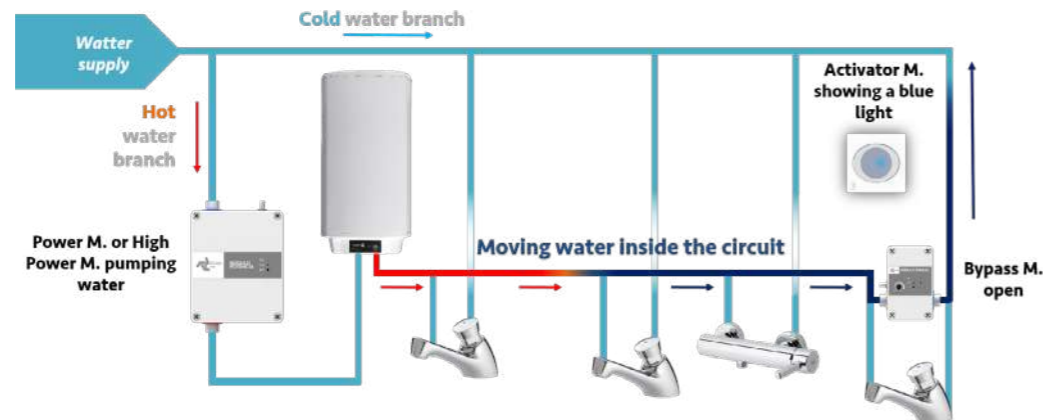

END:

The recirculation cycle stops when the water reaches a certain temperature or after a pre-set time. For 30 seconds, the **Activator Module** illuminates in red colour, meaning hot water is ready.

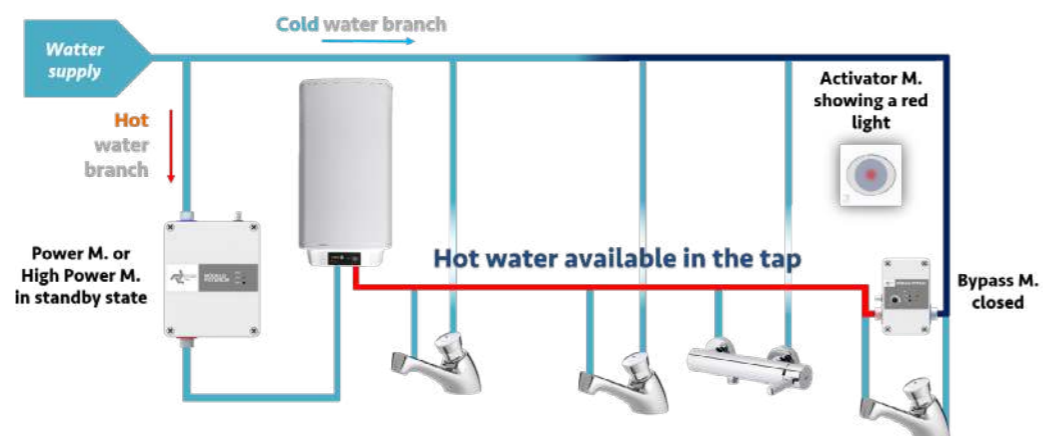

3. OPERATION OF WAISENSE COMFORT

The existential reason of **WAISENSE Comfort** is making your life easier. That is why its interface is so simple. Just hold your hand in front of the capacitive Activator Module and wait for hot water to be ready where you desire.

That's it. Every time you want to use hot water, simply remember to use the Activator Module with all the taps turned off. This is how you achieve smart water living.

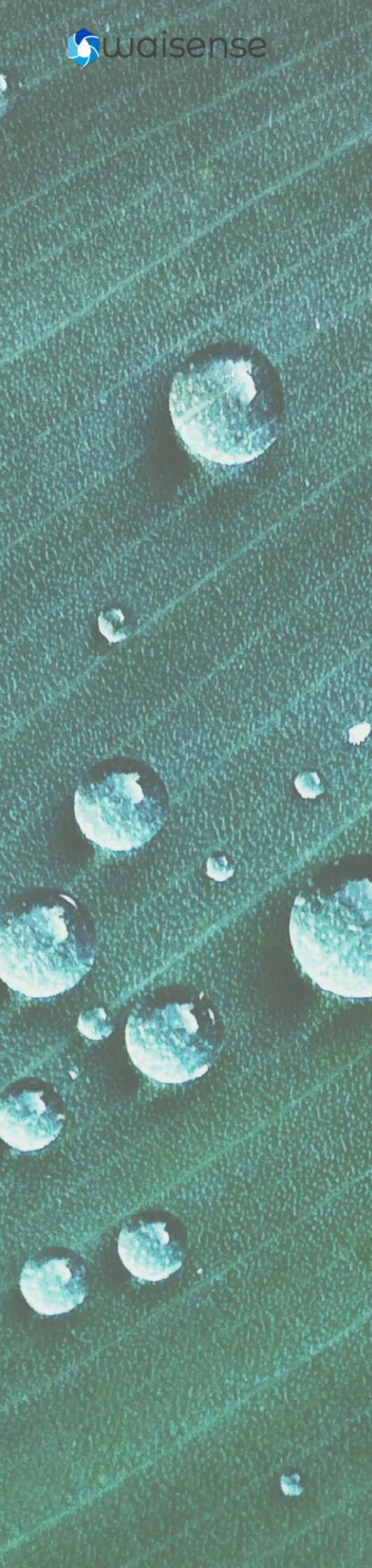

Fiji Version

The **Activator Module** will start to blink in blue while it connects with the rest of the installed modules inside the housing. If this blue light stays still, it means that water is flowing from the **Power/High Power Module** towards the **Bypass Module**. In its course, hot water will flow near all the taps that exist between both modules.



Fiji Version

When warm water passes through the **Bypass Module** at the right temperature (which the user can set from 25°C to 45°C), the **Activator Module** will show a red light. Now you can enjoy hot water without having wasted a single drop.



Fiji Version

As a safety and efficiency method, WAISENSE comfort incorporates a clock that measures if the cycle is taking too long to bring hot water to the **Bypass Module**. This clock makes the system stop automatically after 15 minutes from activation. In that case, the light from the **Activator Module** will turn yellow.

This situation may be the consequence of different events: we have run out of gas or the electric water tank is not plugged in, among others.



4. BENEFITS FOR THE USER

WAISENSE Comfort is made for people like you, who cannot stand observing the huge amount of drinking water that is daily disposed down the drain without being used. In fact, this is the most expensive water, as we pay for it but we do not enjoy it.

Furthermore, we could state that the economic benefits are not the most important feature of **WAISENSE Comfort**. It is the thousands of litres that every family and business will save from now on, taking care of

our shared environment. Just to get a glimpse of what we are talking about, let's take into consideration that a country like Spain consumes 142 litres per user daily (31.2 gallons). **WAISENSE Comfort** can result in savings up to 56% in a typical detached house. For businesses using hot water, this quantity may even increase. Using **WAISENSE Comfort** means over 1,000 litres (200 gallons) saved monthly per user and, obviously, a great improvement if comfort living for you, your family or customers.

How much do I save with this technology?

The savings resulting from **WAISENSE Comfort** usage depends on the water consuming routines of each user: the more hot water we spend, the faster the investment return and the generation of profit. In fact, almost every water supply company applies different prices for different ranges of water consumption, rewarding the users that consume less with a lower tariff. So, the more we save, the cheaper the litre or gallon of water will be.

Also, **WAISENSE Comfort** assures a well-being that has been unaware until now. Most of us may recall the habit of bringing a bucket to the shower to collect the initial cold water and use it later on in cleaning or watering plants. Besides, it happens frequently that a family schedules turns for using the shower, so the hot water is ready at the tap for the next user. All those tiring routines may disappear from your life, switching them for a simple **Activator Module**.

Just imagine: you wake up, then you use the **Activator Module** and start thinking what are you going to wear that day or even having breakfast. When you realize, hot water will be ready to energize your day. This one sounds good too: you get home exhausted after a long day at work, and what's better than activate **WAISENSE Comfort** and take a relaxing shower? The

variety of situations that can become an improved experience are countless, the same amount as there are ways to enjoy hot water at your home.

Moreover, businesses can be benefited too, because, as you may have realized, **WAISENSE Comfort** is not only recommended for housings, but for gyms, hair salons, nursery schools, etcetera. If you own a service company, you may want to stand out with something all your customers will appreciate. It is not only about the innovation; as your customers will notice that you care for our common environment too.

“Embracing and enjoying smart water living has never been so easy”

Using **WAISENSE Comfort** is a way of seizing the day. Think about it: until now, if you cared about not wasting water before becoming hot enough, you were placing your hand in the stream of water periodically to sense its temperature. You were only standing still, wasting your time. **That is all over now. With WAISENSE Comfort you can claim those moments back for whatever you want to do with your time and energy: just do not throw it away like water.**

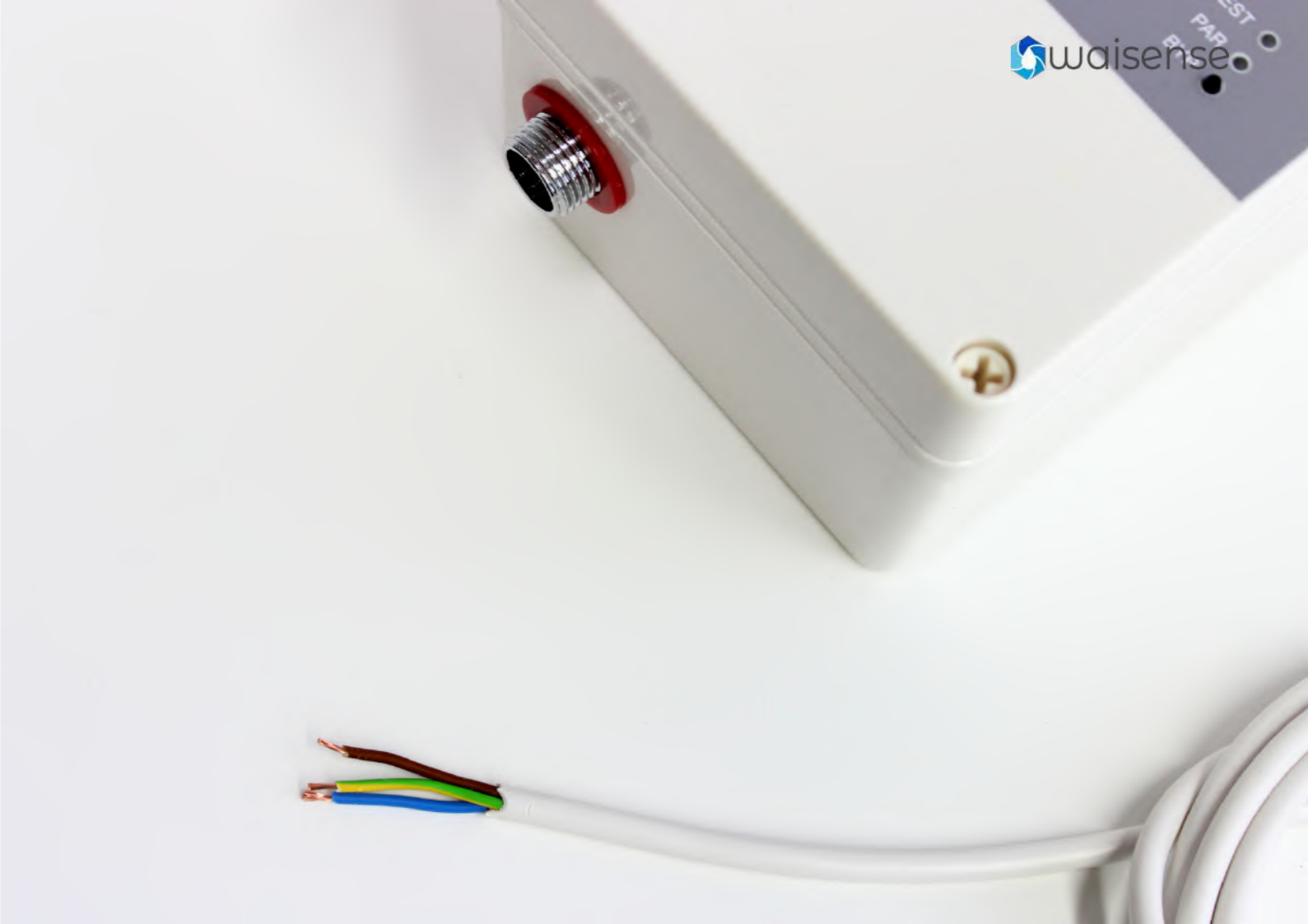

5. INSTALLATION OF WAISENSE COMFORT

The first thing to know about the installation of **WAISENSE Comfort** is that there are many ways of adapting it to your house or business.

The modularity of the system makes it a perfect fit for whatever your needs are and depending on the type and stage of the construction. **WAISENSE Comfort** relies on this main feature for the technology to adapt to your routines, so you do not have to change the way you use hot water. Even though it is a huge innovation, no training period is necessary.

WAISENSE Comfort is compatible with any kind of water heater: solar, electric, gas, fuel and more. The device does not need the addition of extra pipes or water tanks, as it uses the existing plumbing installation and hardware. So, forget about opening walls up to accommodate a dedicated new return branch or about looking for a proper spot to install another hot water tank for water storage.

Naturally, **WAISENSE Comfort** complies with the European and Spanish norms for construction and installation, specifically Código Técnico de la Edificación (CTE), Reglamento Electrotécnico de Baja Tensión (REBT) and Reglamento de Instalaciones Térmicas de Edificios (RITE).

In a typical flat or one-storey house, you will only need one unit of each of the three main modules in order to start enjoying smart hot water. For that purpose, WAISENSE Comfort recommends to begin your plumbing upgrade with a BASIC KIT or a HIGH POWER KIT.

BASIC KIT

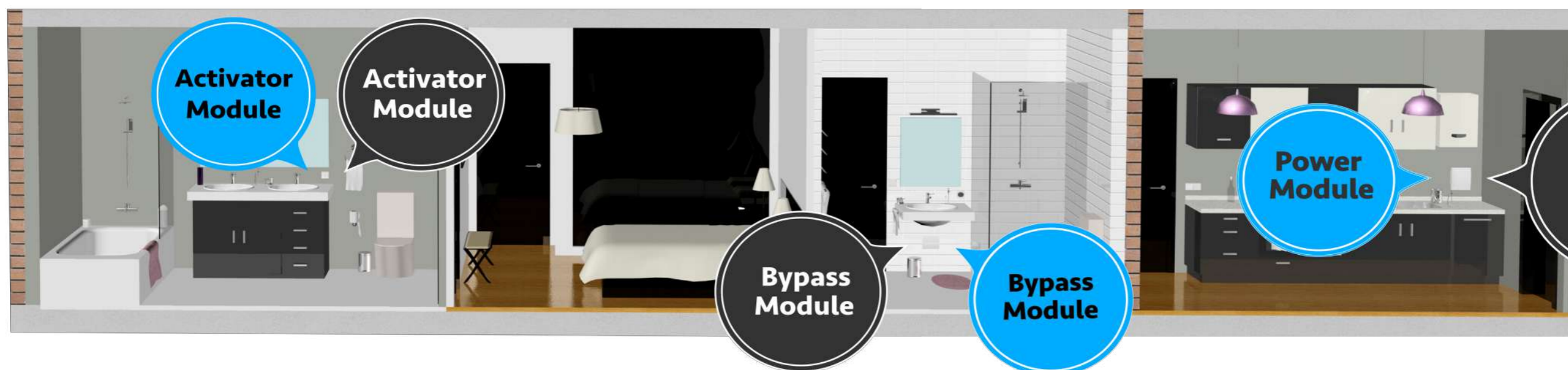

HIGH POWER KIT

The **BASIC KIT** comprises a **Power Module**, a **Bypass Module** and an **Activator Module**. It is recommended mainly for housings up to 80m² (861ft²) with tank water heaters (electric, solar or any other accumulation kind). It is less suited for instant water heaters, as they usually need a higher pressure for starting up.

The **HIGH POWER KIT** includes a **High Power Module**, a **Bypass Module** and an **Activator Module**. With this equipment, you can enjoy smart water technology in installations up to 300m² (3,229ft²). Using instant water heaters, like gas type, is no longer

a limitation.

The mentioned installation surfaces limits are not mandatory, but based on experience. The reality is that there are not two identical installations or users, and that is why we created a versatile system for optimal adaptation.

Any of these kits set the starting point for your installation to become greener and more efficient. Let us check the example below.

In this apartment, the typical arrangement will comprise a **Power/High Power Module** in the cold water line right before the water heater inlet; a **Bypass Module** in the farthest room from the water heater where hot water might be demanded; and an **Activator Module** where its use becomes more intuitive. As you can see in the image, we recommend installing the **Bypass Module** in the farthest room from the water heater so that the rooms with hot water taps in between are preheated too along the cycle.

The **Activator Module** can be attached to any wall inside the facility; may it be within the bathroom or kitchen where the **Bypass Module** will most probably be or in any other common area, like a hall or a corridor. For an instance, let us consider a suite bedroom, with a bathroom in it: if you do not want visitors to enter into the bedroom to activate **WAISENSE Comfort** for another bathroom, you can install an **Activator Module** at the entrance of the room or in the hallway. For optimum comfort, we can add as many **Activator Modules** as wanted: one for every restroom, another one in the kitchen or in any bedroom. In the following pages, you can find the general process of installing every module of **WAISENSE Comfort**. Take into account that jobs in the walls are optional for a more elegant look. **Whatever you need and whatever you desire: you decide.**

Process description

The installation method takes up to three stages:

- **Distribution of the modules in the installation and synchronization routine.**
- **Plumbing installation.**
- **Electric connections.**

The first stage is perhaps the most important, as it defines the performance of the device in the housing or business. It consists on identifying the best location for installing every module of **WAISENSE Comfort**, checking the correct wireless communication between each module. This verifying part of the process is what we call "synchronization".

After the first synchronization routine, you may want to test that the communication is successfully established by initiating a cycle using the **Activator Module**: you will hear a click in the **Bypass Module** and the **Power/High Power Module** will be vibrating.

Once the communication has been checked in the final layout of the modules, it is time to start the plumbing and electrical installation. At this point, we can distinguish two ways of executing the installation of the modules: accommodating each one inside a hole in the wall or leaving them fixed to the surface of the wall. Both possibilities have their own advantages: check which one matches your style better.

In the case that you are not confident enough on which type of installation is best for you, do not forget **WAISENSE Comfort** is always ready to assist you in any matter related to **WAISENSE Comfort** and its applications.

Modules installed inside the walls

In this type of installation, the plumbing and electrical connections take place inside the wall, in a hole hidden by an elegant cover.

This type of installation is recommended mainly for houses or other facilities that are about to be built

or refurbished. In this scenario, the holes in the walls and the plumbing and electrical connections could be planned previously, so there is no extra effort in accommodating the modules inside the walls. You can use the cover provided for the **Power/High Power** and **Bypass Modules** to hide the hole with an aesthetic finish.

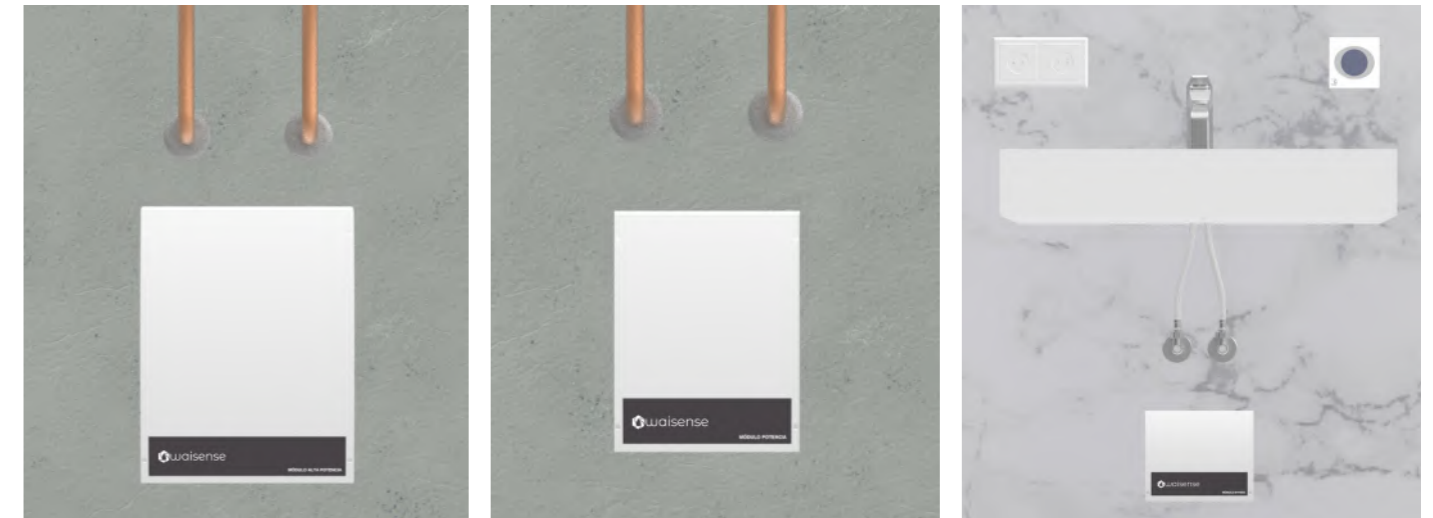

Cover for the High Power Module

Cover for the Power Module

Cover for the Bypass Module

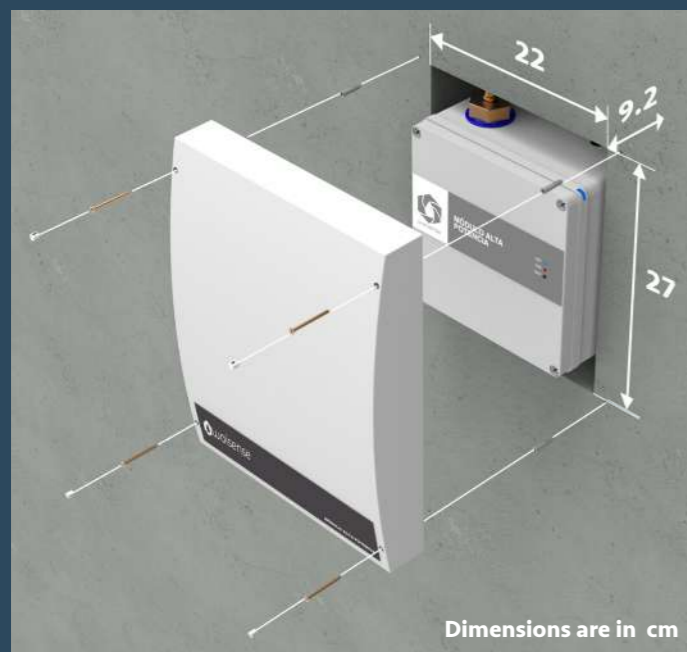

Dimensions of a High Power Module installed inside the wall

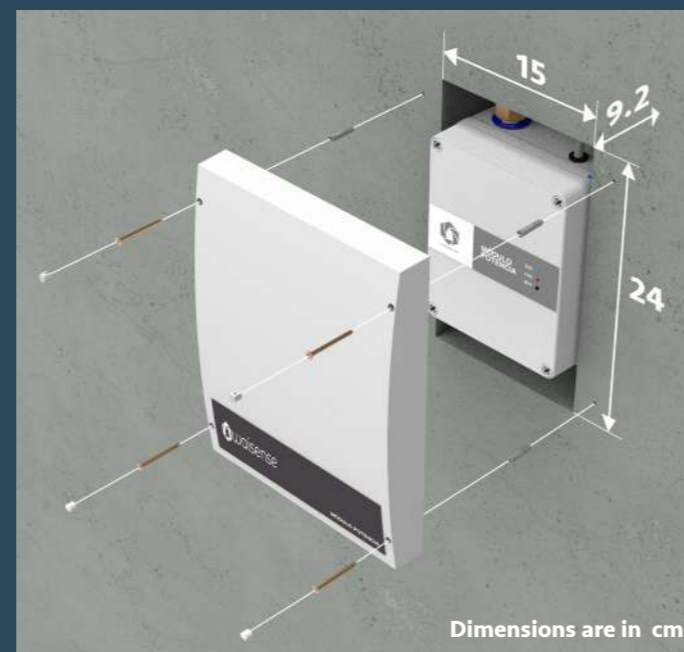

Dimensions of a Power Module installed inside the wall

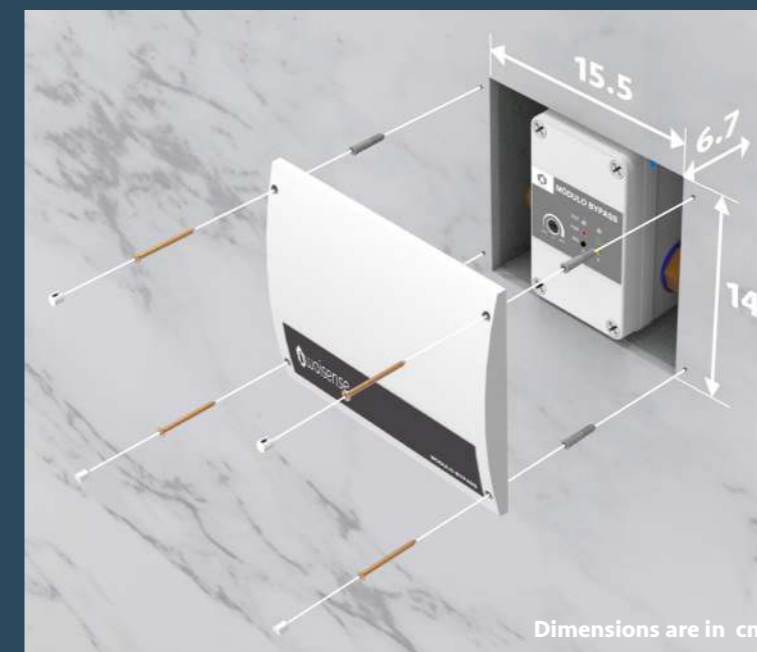

Dimensions of a Bypass Module installed inside the wall

The images on the left side show the dimensions of the holes for every module, as well as the drills for the screws to attach the cover to the wall.

The **High Power Module** uses 1" threads for plumbing connections, while the **Power Module** and the **Bypass Module** use 1/2" instead. From any junction box or distribution panel, new electric lines must be conducted to the new hole in the wall where the **Power/High Power** or **Bypass Modules** is placed. The **Power/High Power Module** need ground connection, while the **Bypass Module** only requires phase-neutral. After all the electric and plumbing connections have been made and the correct performance of the cycle has been tested, the hole can be hidden with the corresponding cover.

Modules mounted over the walls

This superficial type of layout for the modules eliminates the need of opening up holes in the walls, granting a quicker installation process.

As it was mentioned earlier, there are multiple installation possibilities and finishes and, consequently, the **Power/High Power** and **Bypass Modules** can be directly attached to the walls without executing any big openings, just a few drills. To fix the modules to the wall, you must use the wall plugs and screws provided with each one (the same the module cover uses). Every module can connect to the plumbing using rigid or flexible pipes. Finally, adding a plug to the end of the modules wiring, allows you to connect them to a power supply socket.

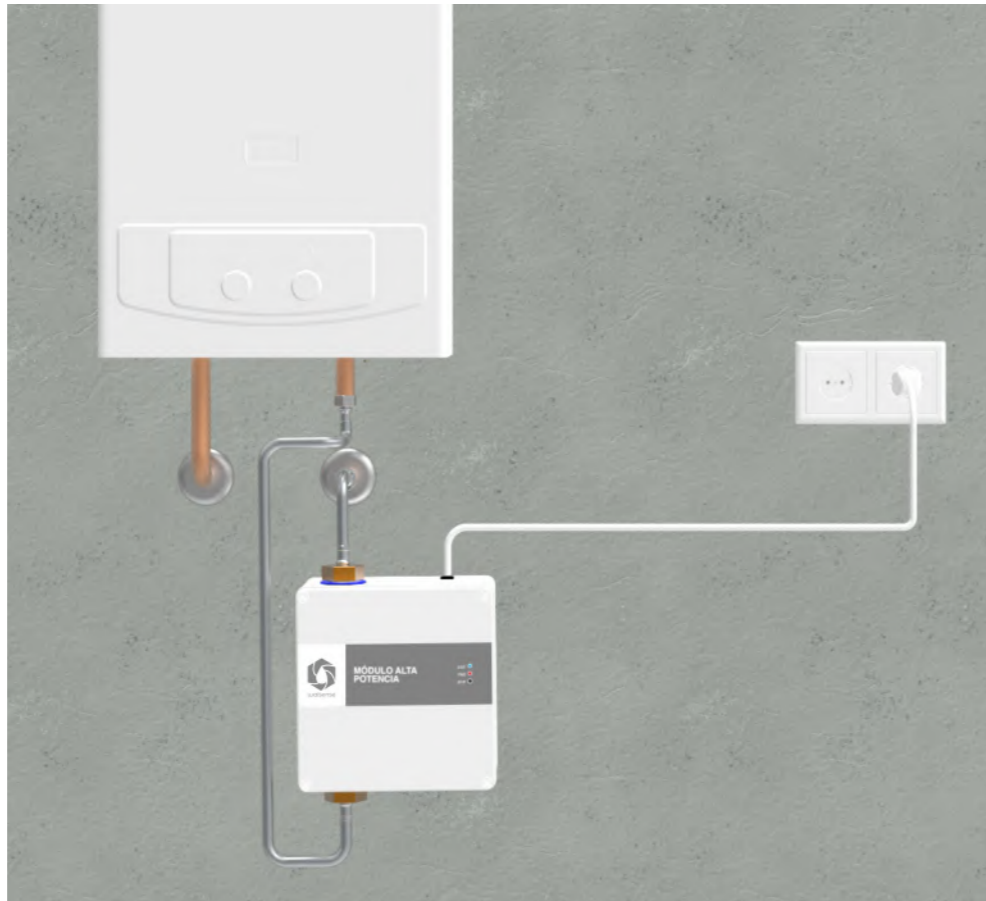

Possible layout of Power Module mounted over the wall

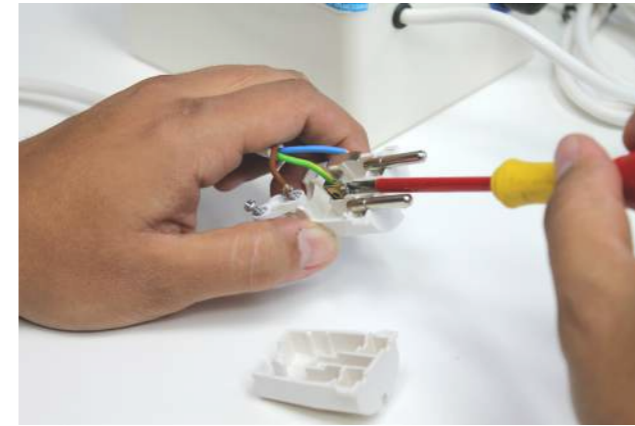

Connecting the modules to the electricity is as easy as adding a plug at the end of the wires. Only the **Power** and **High Power Modules** require ground connection.



There is no need for ground connection when adapting a plug to the **Bypass Module**.

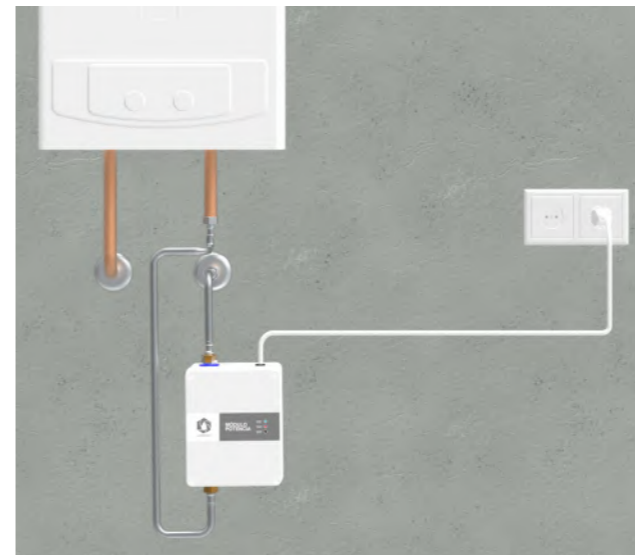

Possible layout of High Power Module mounted over the wall



Possible layout of Bypass Module mounted over the wall



Dimensions of the High Power Module mounted over the wall

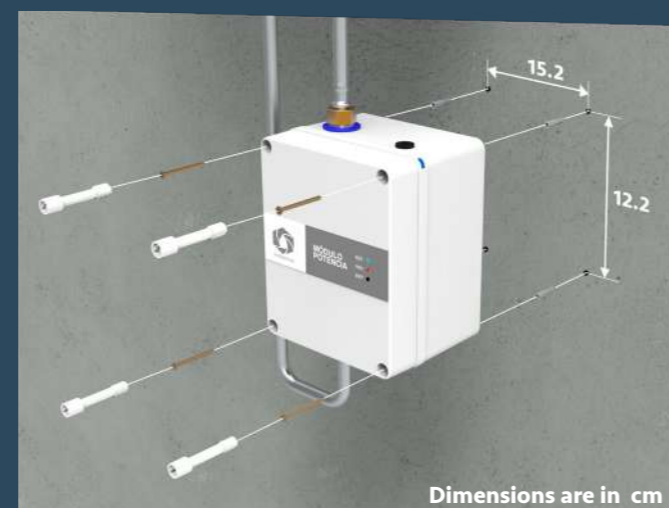

Dimensiones del Módulo de Potencia en Instalación en Superficie



Dimensiones del Módulo de Bypass en Instalación en Superficie

In order to mount the **Power/High Power** and **Bypass Modules** over the walls a simple procedure must be followed. First of all, four drills must be made, using the dimensions on the images below to know the separation needed between each hole. Then, we introduce the wall plugs provided in each drill. One by one, we extract a plastic screw from the front side of the module, introducing a metal screw in its place, screwing it to the wall plug and re-inserting the plastic screw back. This operation is executed in one corner of the module at a time to facilitate the installation process and to prevent damage to the warranty seal.

Activator and Repeater Modules

It is much easier to install the **Activator** and **Repeater Modules** than the other ones, as they only need the connection to the electric grid. You can find a perfect spot where there is a phase-neutral electrical line, like in a wall socket. These modules adapt to an universal wall mounting box or cassette, where the electrical connection is made. The operation ends by assembling the translucent cover or blind cover and the frontal frame over the corresponding module.

Furthermore, it may be even unnecessary to stuck a new universal wall mounting box for the **Activator** and **Repeater Modules**, as you can refurbish one socket or similar that is not commonly used. The pictures on this page show how to perform an installation of an **Activator Module** from an existing power supply socket. In any case, remember that the location of the **Activator Module** inside the facility must be intuitive for the interaction of the user, while the **Repeater Module** must be placed where communication with other modules is effectively increased.

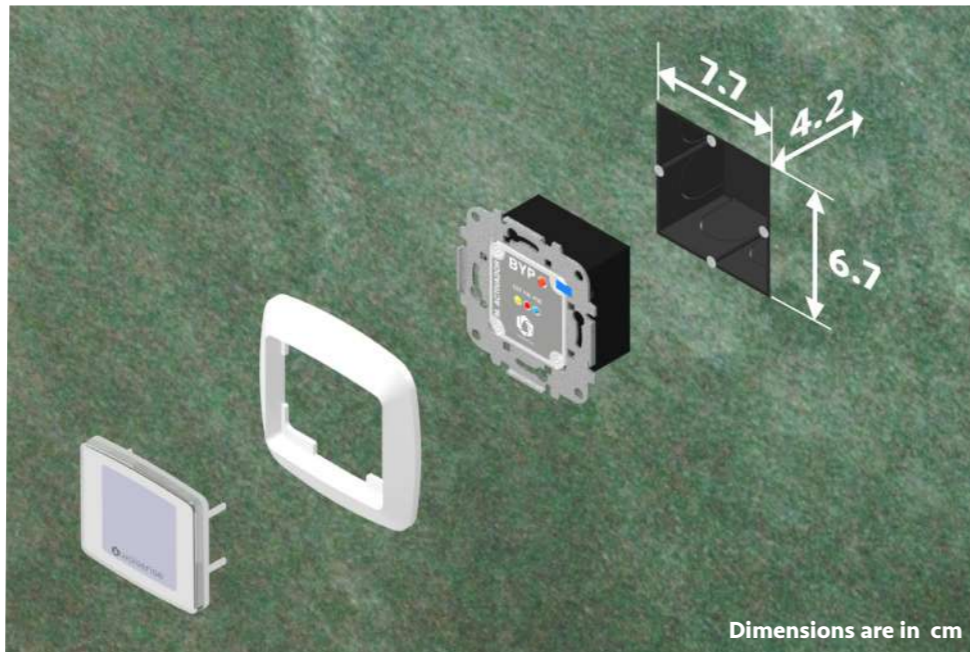

Activator Module. Jamaica Version.



1. Remove the frontal frame and cover of the socket.



2. Unscrew the rest of the structural frame and mechanism, unplugging the electric lines.



3. Hold the **Activator** or **Repeater Module** and plug the phase and neutral wires to the rear of the module using a screwdriver.



4. Use it again to attach the metallic frame of the module to the existing metal frame of the universal wall mounting box.



5. Insert the corresponding translucent cover or blind cover and frontal frame to finish the installation.

WAISENSE Comfort is available in two design lines, called **Fiji** and **Jamaica**. Both families of product have exactly the same features and working functions, being their only difference the aesthetics of the **Activator** and **Repeater Modules**. **Presto Version** deploys a family friendly and timeless design with curved lines, while **Galindo Version** reflects a more modern and outstanding look combining right angles with a centred oval shape.

In the case of the On-Battery Activator Module its installation offers the option of being carried out without a power supply line close. Since you don't need a network connection, you only need to perform the following steps:

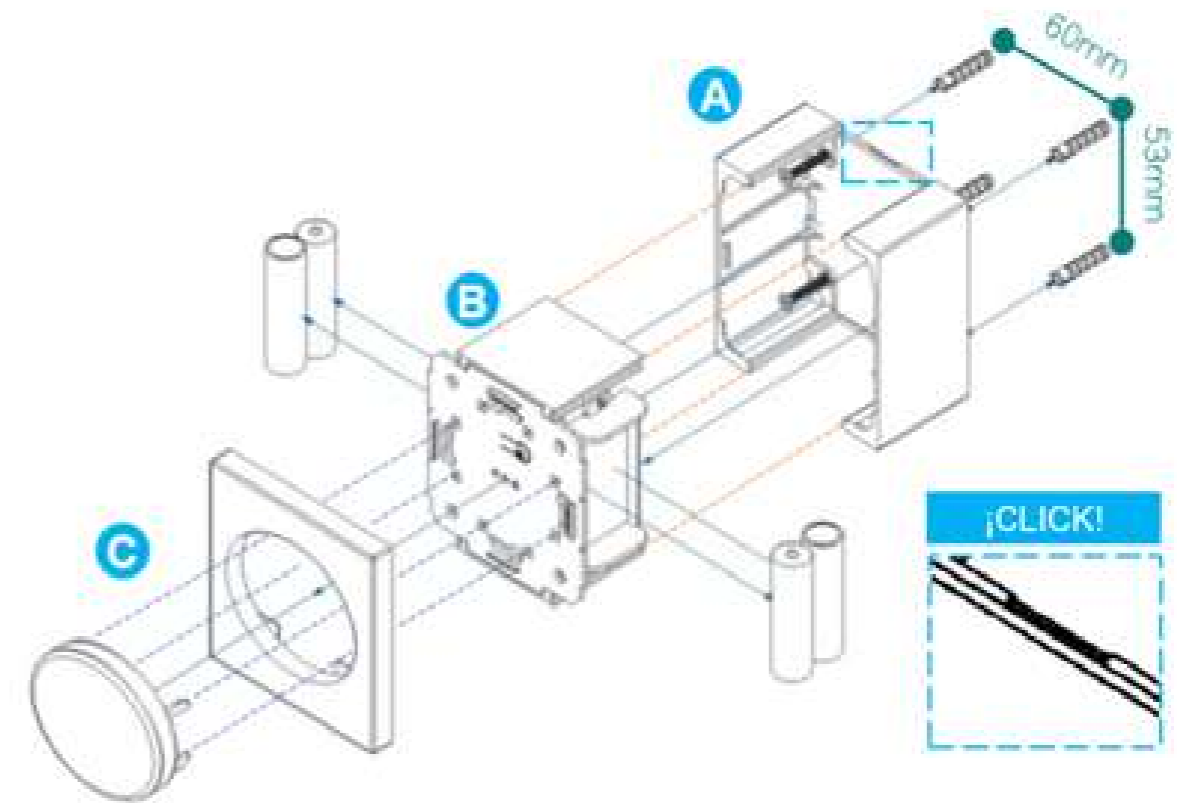

1. Drill some holes at the marked distances. Remove the base (A) of the assembly by pressing on the upper and lower faces of the frame assembly (B) and screw the wall.

2. Reassemble the frame assembly (B), with the batteries included, in the base (A) anchored to the wall through the available rails, until the upper and lower flanges fit.

3. Finally, mount the frame and beacon pair (C), placing the frame on the frame assembly (B), and inserting the beacon claws into the 4 holes of the frame (B), thus being correctly fixed.



Expanding Waisense Comfort

WAISENSE Comfort adapts to every person and every type of installation: houses or businesses, new and old. The modularity is the key feature of this innovative technology and the reason behind the smart water service it offers. As a result, the five different modules in **WAISENSE Comfort** can combine in many ways.

As stated before, for a flat or one-storey building, a **BASIC KIT** or a **HIGH POWER KIT** were enough to start enjoying the benefits of **WAISENSE Comfort**. In the case that the installation comprises more than one floor, another pair of a **Bypass Module** and an **Activator Module** will be needed for every new floor where the recirculation service is desired. The couple formed by a **Bypass Module** and an **Activator Module** is called **EXPANSION KIT**.

What is more, we can add as many **Activator Modules** as wanted, just to boost the comfort in using the smart hot water, initiating the cycle from every place in the housing or office.

Finally, to guarantee the wireless communication between all modules, one or more **Repeater Modules** may be needed, especially, when there are large distances or communication obstacles in between any pair of modules.

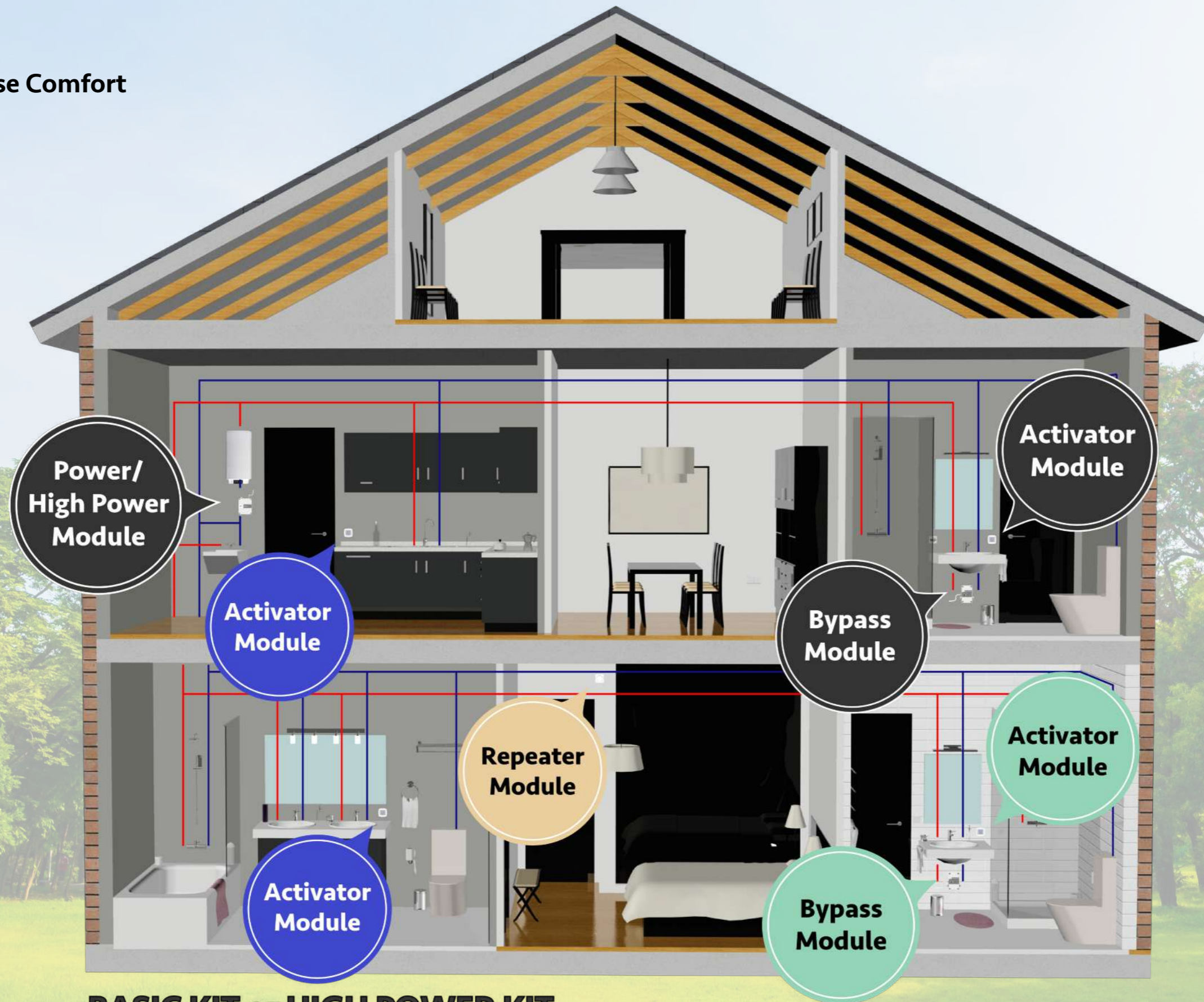

BASIC KIT or HIGH POWER KIT
EXPANSION KIT
ADDITIONAL ACTIVATOR MODULE
ADDITIONAL REPEATER MODULE

Combinations are countless. Each **Power** or **High Power Module** can control as many **Bypass Modules** as recirculation circuits we want to manage. In addition, every **Bypass Module** can be associated to as many **Activator Modules** as desired, obtaining a more efficient and comfortable living space, activating hot water from wherever we want to.

Starting from a functioning **BASIC KIT** or **HIGH POWER KIT**, with their provided modules successfully synchronized, you only need to link every new purchased module to the functioning ones to integrate them into the **WAISENSE Comfort** working units. As stated previously, the synchronization process allows the modules to identify each other and to know what quantity and type of units are installed.

The synchronization routine is indeed very simple. Only a few steps and **WAISENSE Comfort** will be ready for you to start enjoying it.

The process itself includes two stages, that must be executed in a determined order. The first step will link the **Power/High Power Module** with the **Bypass Module**. Once this is done, the second step consists on pairing the **Bypass Module** with the **Activator Module**.

The reason for the colour of the buttons and LED lights in the modules is in fact to simplify the overall procedure:

BLACK BUTTON. Located in the **Power/High Power Modules** and the **Bypass Module**, in order to link them.

ORANGE BUTTON. Located in the **Bypass Module** and the **Activator Module** for the same purpose.



Stage 1:

This first part of the synchronization process consists on associating the **Power/High Power Module** with the **Bypass Module**:

1. Push the black button in the **Bypass Module** for at least 5 seconds, until the "EST.P" LED starts blinking in white.

2. Now push the other black button in the **Power or High Power Module**, waiting for the same response.

3. Both modules will continue blinking until they recognize each other. When the matching is successful, "PAR.P" LED in the **Bypass Module** and "PAR" LED in the **Power or High Power Module** will illuminate in green, steadily for 30 seconds.

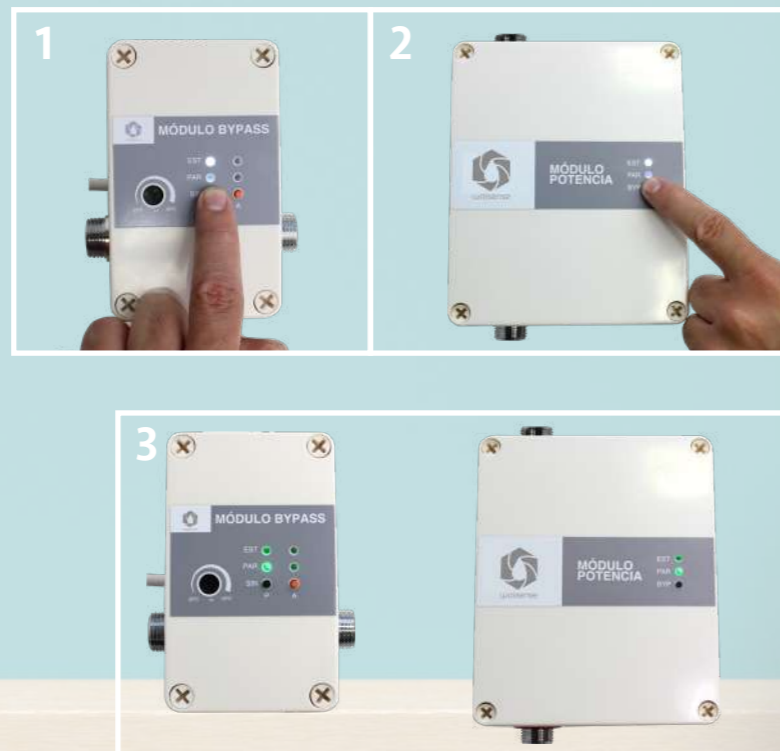

Stage 2:

The last stage comprises the pairing of the **Bypass Module** with the **Activator Module**:

1. Press now the orange button in the **Activator Module** for at least 5 seconds, until the "EST" LED blinks in yellow.

2. Finally, push the orange button in the **Bypass Module** for the "EST.A" to begin emitting a white blinking light.

3. These two modules will continue in this state till they identify each other. If this final link results correct, "PRE" LED in the **Activator Module** will glow in blue for 30 seconds as the "PAR.A" LED in the **Bypass Module** will show a permanent green light for the same amount of time.

For adding new modules to the installation, just repeat the corresponding sequence.

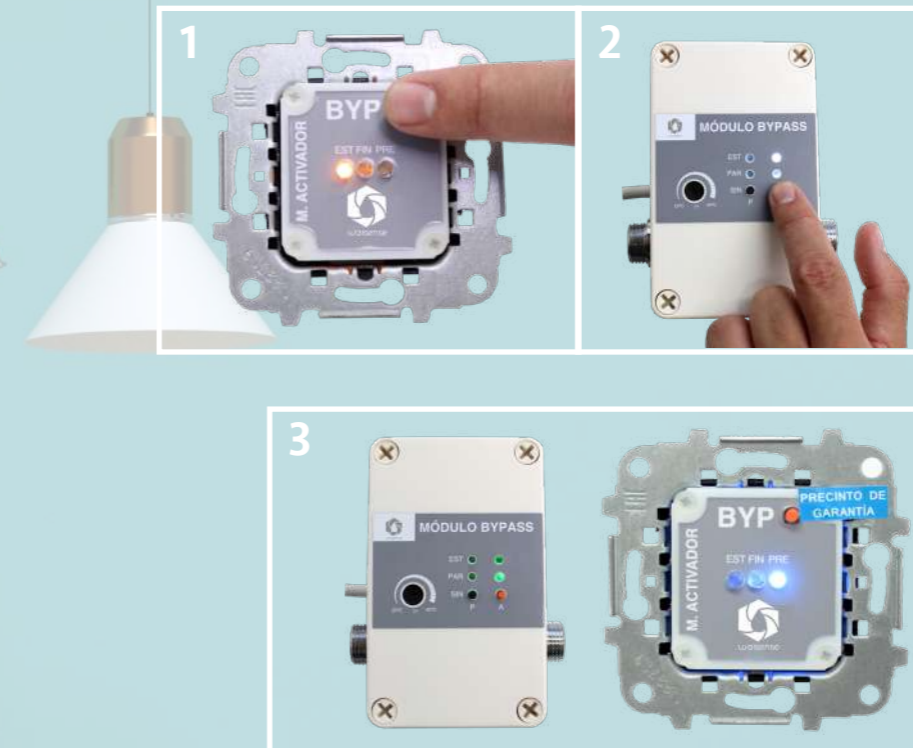

REPEATER MODULE

A large separation between modules or the existence of obstacles may interfere in the proper wireless communication of the modules. In the scenario where, after a second or a third try, a couple of modules is not yet interconnected or synchronized, there are two alternatives: changing the location of the modules inside the installation, so the ones that do not communicate become closer; or adding a **Repeater Module** to the equation, located in between the modules that have communication issues.

This module does not need any synchronization routine, as it starts repeating the communication signal from the moment it is connected to the electric line.

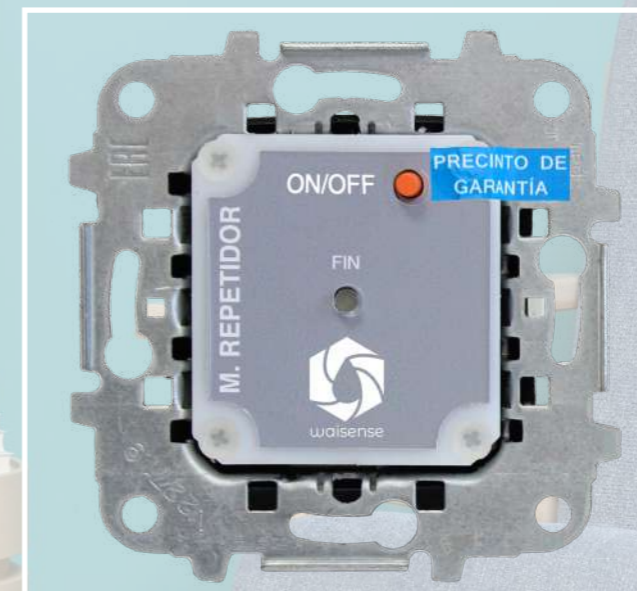

With all these explanations, we are ready to include the smart water **WAISENSE Comfort** in our home, business or in our new or refurbished building.

As simple as it may be, **we** recommend that the installation and first start of **WAISENSE Comfort** is executed by experienced installers or other related technical professionals. Ask your retailer for more information.

Description of the modules

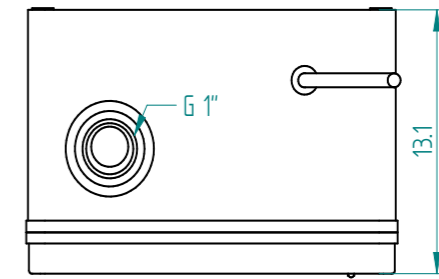
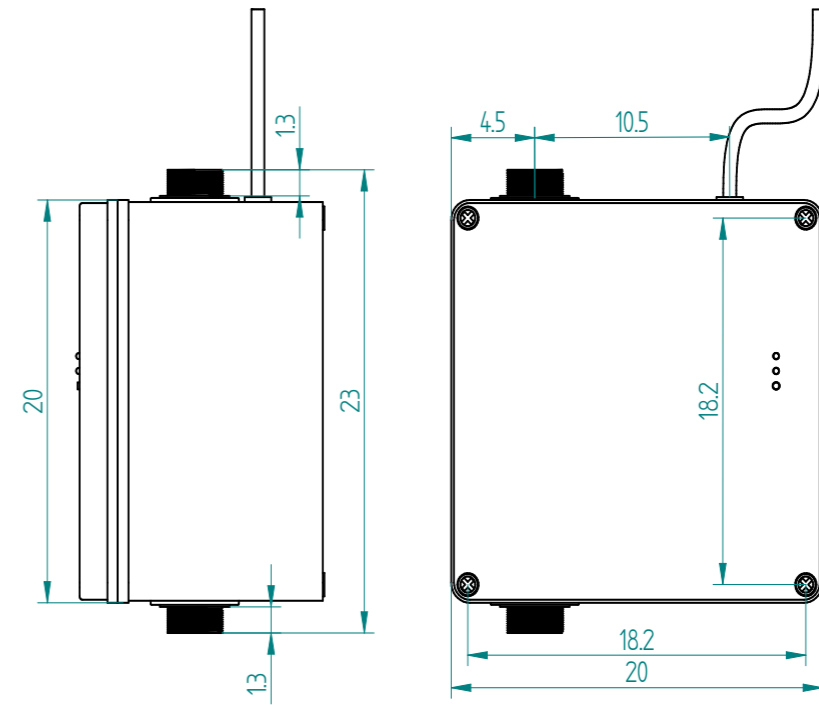

HIGH POWER MODULE	
Weight	5.4kg
Voltage	230V
Frequency	50-60Hz
Intensity	1.50A
wiring (3m-3x1,5mm ²): BLUE: Neutral BLACK OR BROWN: Phase GREEN AND YELLOW: Ground	
Maximum Power	350W
Nominal Power	320W
Minimum Power	160W
Standby Power	<2W
Maximum Height	15m.c.a.
Maximum Flowrate	75l/min
Maximum operating pressure	800kPa
Operating temperature range	0-35°C
Protection thermostat	70°C
Maximum temperature	110°C
Estimated wireless communication range	25m

HIGH POWER MODULE COVER	
Weight	0.38kg
Cover caps	4units.
Drills for cover fixation (4)	Ø5x25mm
Fixation screws (4uds.)	3x45mm
Fixation plugs (4uds.)	Ø5x25 mm

The **HIGH POWER MODULE** should be located just before the cold water enters the water heater. It is responsible for pumping hot water during the recirculation cycle.

Using a **HIGH POWER MODULE** instead of a regular **POWER MODULE** will depend on the characteristics of the plumbing installation, taking into consideration that the **HIGH POWER MODULE** has superior capacities in height and flowrate.

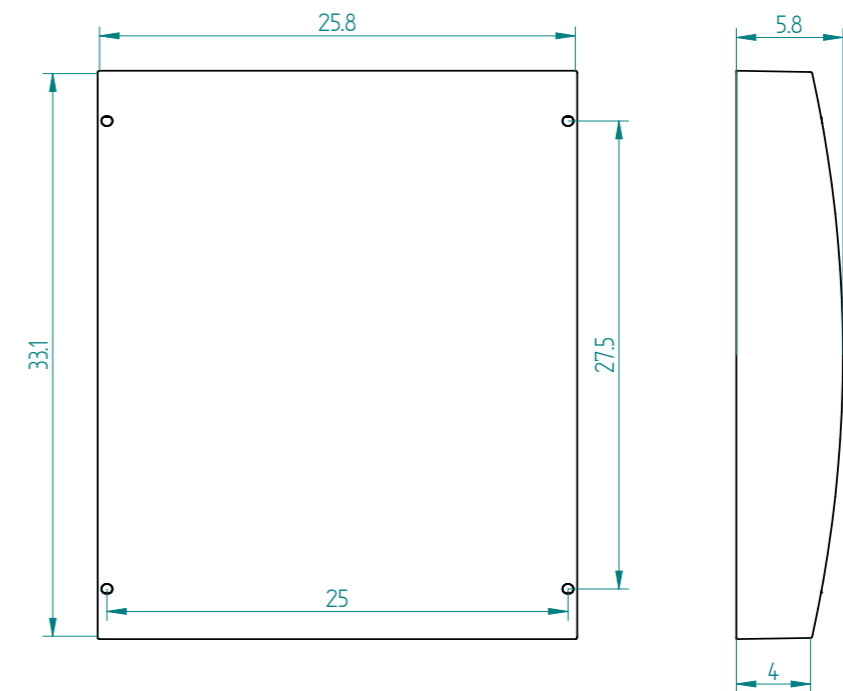

Dimensions in centimetres



POWER MODULE	
Weight	3.5kg
Voltage	230V
Frequency	50-60Hz
Intensity	0,65A
wiring (3m-3x1,5mm ²): BLUE: Neutral BLACK OR BROWN: Phase GREEN AND YELLOW: Ground	
Maximum Power	100W
Nominal Power	90W
Minimum Power	46W
Standby Power	<2W
Maximum Height	6m.c.a.
Maximum Flowrate	40l/min
Maximum operating pressure	800kPa
Operating temperature range	0-35°C
Protection thermostat	70°C
Maximum temperature	110°C
Estimated wireless communication range	25m

TAPA EMBELLECEDORA DEL MÓDULO DE POTENCIA	
Weight	0.2kg
Cover caps	4units.
Drills for cover fixation (4)	Ø5x25mm
Fixation screws (4uds.)	3x45mm
Fixation plugs (4uds.)	Ø5x25mm

The **POWER MODULE** has the same working principle and installation process than the **HIGH POWER MODULE**, but with standard characteristics in height and flowrate, adapting to the majority of facilities.

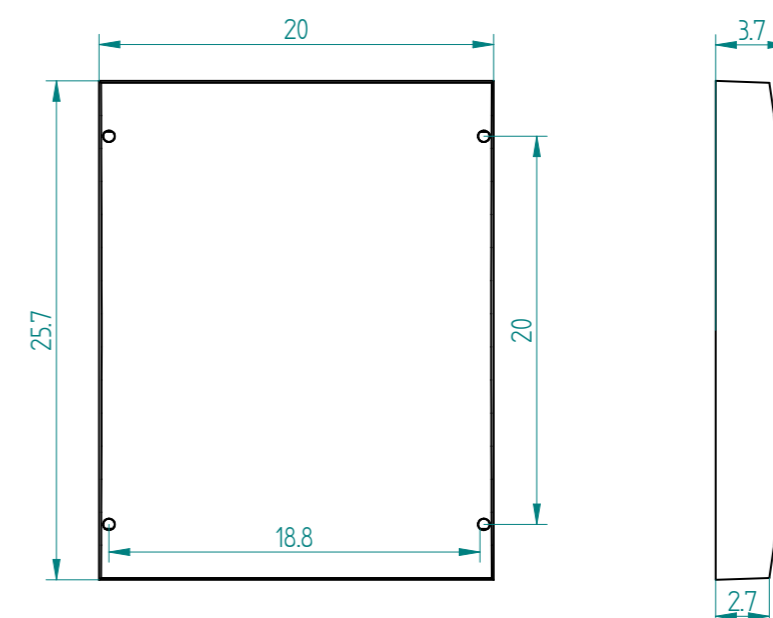
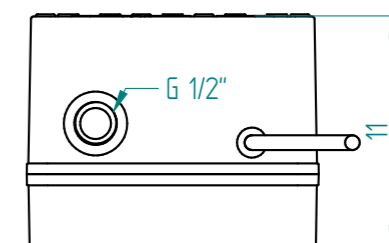
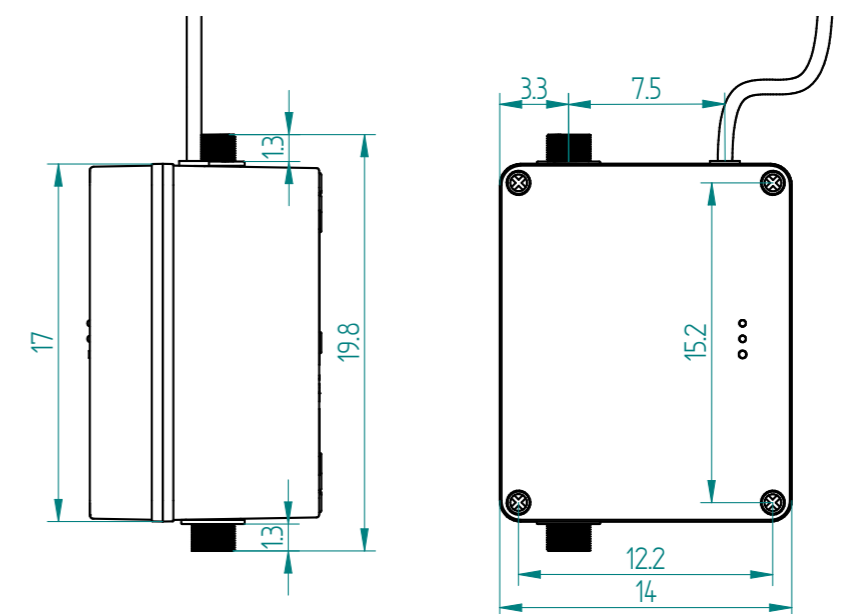

Dimensions in centimetres

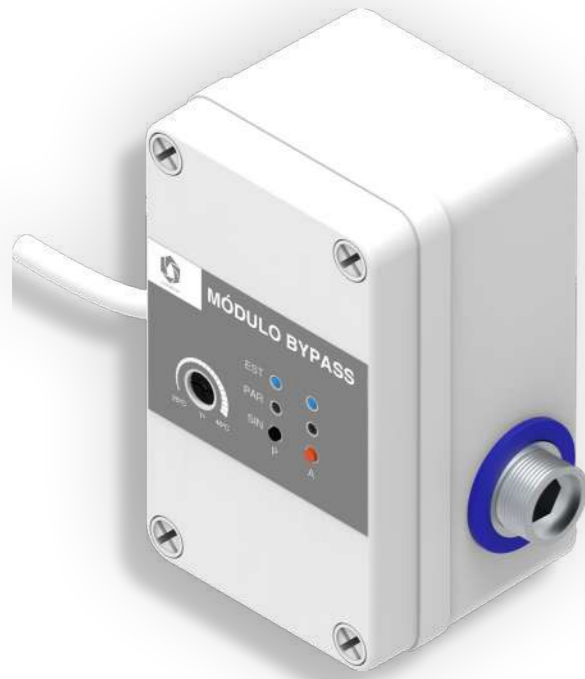

BYPASS MODULE	
Weight	0.95kg
Voltage	110-240V
Frequency	50-60Hz
Intensity	34mA
CWiring (3m - 2x0.75mm ²): BLUE: Neutral BLACK OR BROWN: Phase	
Maximum Power	5W
Standby Power	<1W
Maximum operating flowrate	80l/min
Maximum operating pressure	800kPa
Operating temperature range	0-35°C
Selectable cycle ending temperature	25-45°C
Estimated wireless communication range:	25m

BYPASS MODULE COVER	
Weight	0.1kg
Cover caps	4
Drills for cover fixation (4)	Ø5x25mm
TFixation screws (4 units)	3x30mm
Fixation plugs (4 units)	Ø5x25mm

The **BYPASS MODULE** communicates the hot water branch with the cold water branch temporarily when the cycle is active by means of an inner electronic valve. When the cycle is over, this channel between pipes closes.

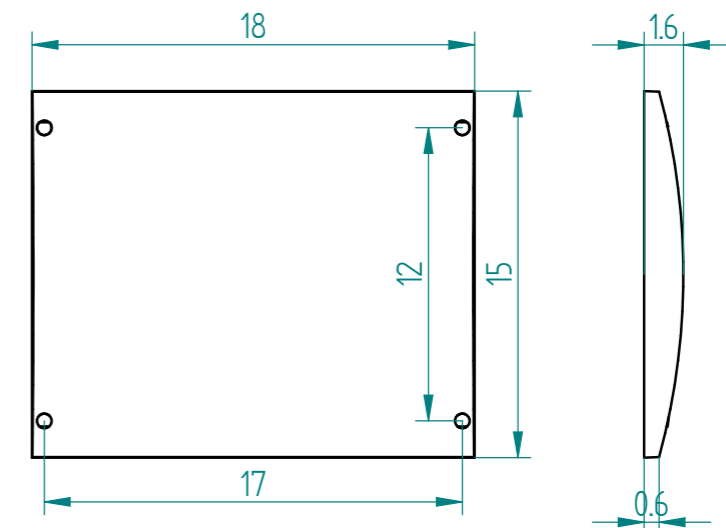
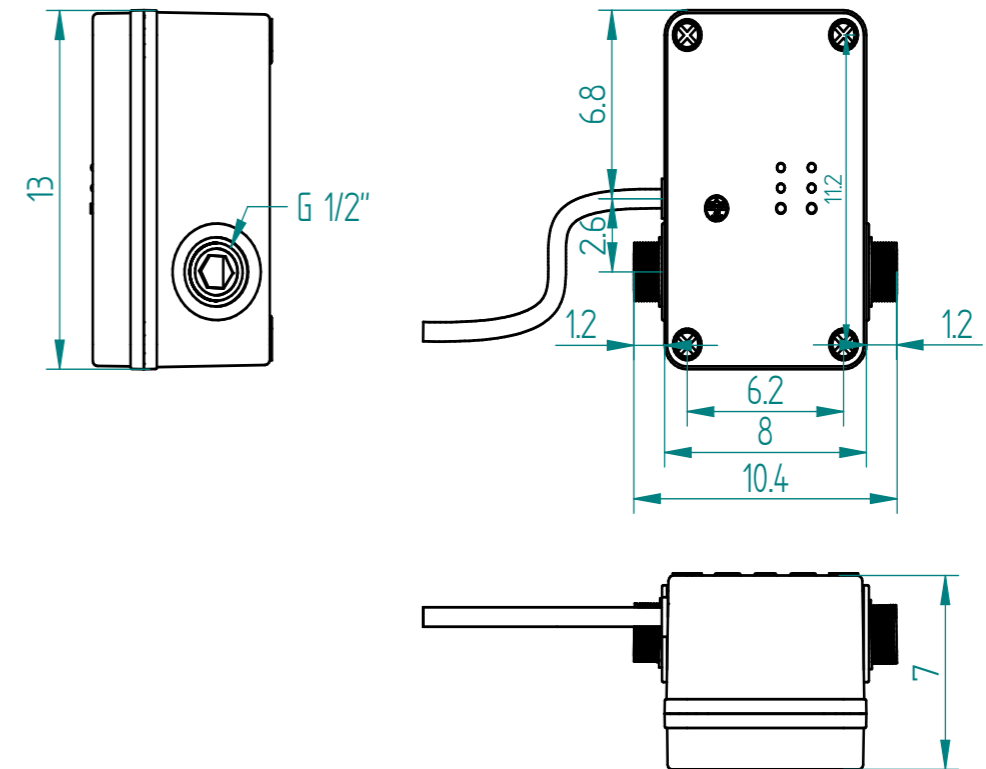



Fiji Version



Jamaica Version



Fiji Version



Jamaica Version



Fiji Version



Jamaica Version

Dimensions in centimetres

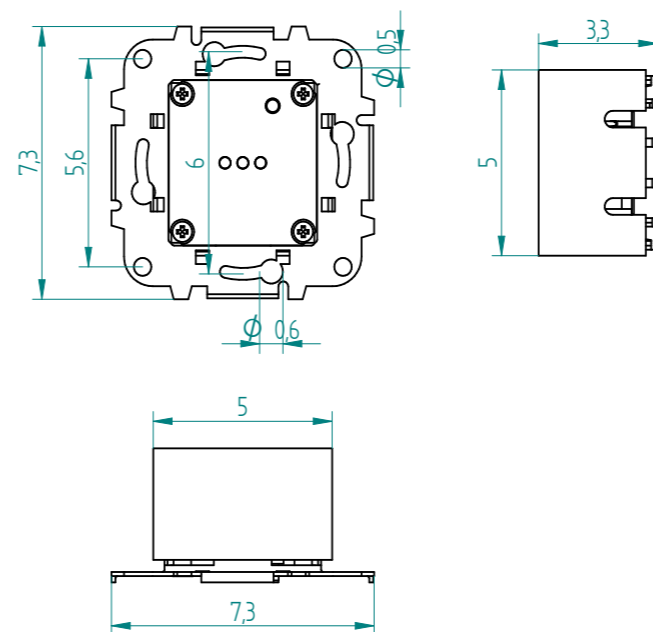

ON-GRID ACTIVATOR MODULE	
Weight	0.2kg
Voltage	110-240V
Frequency	50-60Hz
Intensity	max. 34mA
Maximum Power	1W
Opening temperature range	0-35°C
Estimated wireless communication range	25m

The **ON-GRID ACTIVATOR MODULE** is in charge of starting the cycle when the user wants hot water, showing its state as a coloured light through the translucent cover.

The inclusion of the **REPEATER MODULE** in an installation is optional. If, under any circumstance, there are at least a pair of modules that does not communicate properly, it may be necessary to add a **REPEATER MODULE** in between them in order to make it possible, increasing that way the operating wireless communication range of **WAISENSE Comfort**.

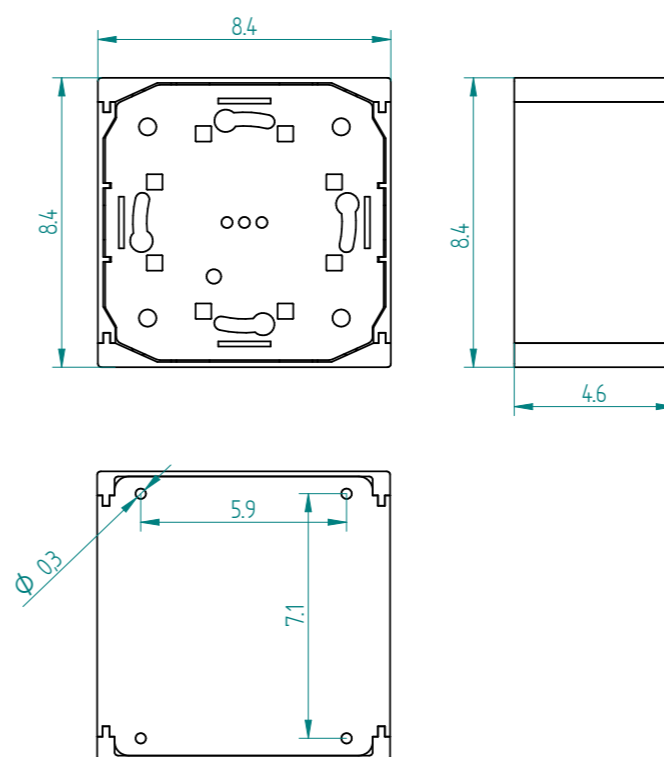

ON-BATTERY ACTIVATOR MODULE	
Weight	0.4 kg
Voltage	3V
Battery type	AA/LR6
battery number	4
Operating temperature range	0-35°C
Estimated wireless communication range	25m

The **On-Battery Activator Module** with batteries does the same function as the Conventional Activator Module connected to the network, using four removable batteries as power supply.

6. PRODUCTS CATALOGUE

WAISENSE Comfort can become a part of your life in different forms. Both kits and individual modules are available in the Fiji and Jamaica version.

THE KITS

HIGH POWER KIT

Experience the comfort of the smart hot water at its full potential with this **HIGH POWER KIT**. As stated before, it is recommended for installations using an individual hot water heater of any type, in houses or business up to 300m².

Contents A: 1 High Power Module, 1 Bypass Module and 1 On-Grid Activator Module.
Contents B: 1 High Power Module, 1 Bypass Module and 1 On-Battery Activator Module.

A (PVP 814,50€)

B (PVP 878,70€)



Type A Kit-Fiji Version



Type A Kit-Jamaica Version

BASIC KIT

The usual way to start enjoying the benefits of **WAISENSE Comfort** is acquiring the **BASIC KIT**, which is suggested for any installation up to 80m² and individual tank water heaters (like solar, electric or fuel).

Contents A: 1 Power Module, 1 Bypass Module and 1 On-Grid Activator Module.
Contents B: 1 Power Module, 1 Bypass Module and 1 On-Battery Activator Module.

A (PVP 599,50€)

B (PVP 664,40€)



Type A Kit-Fiji Version

Type A Kit-Jamaica Version

KIT EXPANSIÓN

Extend the benefits of **WAISENSE Comfort** to additional plumbing branches or floors incorporating an **EXPANSION KIT** into your system.

Contents A: 1 Bypass Module and 1 On-Grid Activator Module.
Contents B: 1 Bypass Module and 1 On-Battery Activator Module.

A (PVP 332,30€)

B (PVP 396,50€)



Type A Kit-Fiji Version

Type A Kit-Jamaica Version

THE MODULES

If the kits do not match what you need exactly, you can always make combinations of individual modules.

HIGH POWER MODULE

(PVP 514,50€)



POWER MODULE

(PVP 261,50€)



BYPASS MODULE

(PVP 214,30€)



ON-GRID AND ON-BATTERY ACTIVATOR MODULE

(PVP 118,00€)

(PVP 182,20€)



On-Grid Fiji and Jamaica Version



On-Battery Jamaica and Fiji Version

MÓDULO REPETIDOR

(PVP 118,00€)



Fiji Version

Jamaica Version



7. FAQs

• **My building has community hot water supply; can I get WAISENSE Comfort in my house?**

The current version of **WAISENSE Comfort** aims at installations with individual water heaters. This means that, unfortunately, you could not incorporate **WAISENSE Comfort** in your house without any plumbing modifications. Nevertheless, as the experience shows, these modifications may be simple and inexpensive, so do not hesitate to ask our technicians for a customized solution.

• **Does WAISENSE Comfort interrupt the flow of water while the cycle is active?**

No, it does not. **WAISENSE Comfort** never stops water from reaching any tap. In fact, if the user turns any tap on during the recirculation process, water will pour from that tap. The only consequence is that it will not be warm enough, as long as the cycle is still running.

• **So, can I use water during the recirculation cycle?**

WAISENSE Comfort sends hot water from an existing individual water heater towards the **Bypass Module**. This module permits the flow of water from a hot water pipe to a cold water pipe until it detects that water has reached the selectable cycle ending temperature (from 25-45°C). While the **Bypass Module** is open, cooled water from the hot water pipe is introduced in the cold water pipe in reverse direction. This behaviour continues until the cycle stops or while all the taps are turned off.

In case there is some kind of consumption during the cycle (from a tap, a washing machine...) the process will be interrupted, and water will normally flow from the water supply towards the point where it is being used. Nevertheless, this scenario might occur seldom, as the cycle lasts a maximum of 15 minutes, so the chances of this happening in 24 hours are not very representative.

• **Do I need a Bypass Module for each tap?**

No, you do not. At least one **Bypass Module** is required for every hot water branch existing in the installation where the user wants to enjoy **WAISENSE Comfort** benefits. These branches consist of a main pipe and its ramifications for every tap or domestic hardware using water. There is usually one branch for every floor of the housing.

By installing the **Bypass Module** in the farthest room from the water heater, the recirculation will pre-heat the main pipe of the branch in that level. In any case, if two rooms using hot water are the same floor but much separated from each other, the user can add as many **Bypass Modules** as he/she wants, taking into consideration that each **Bypass Module** needs at least one synchronized **Activator Module**.

• **Is it possible to use an Activator Module in the kitchen to prepare hot water in the bathroom?**

Yes, indeed. If the **Bypass Module** is located at the end of the branch that supplies both the kitchen and that bathroom, whenever the cycle is executed, hot water will flow through the whole main pipe of the branch. Thus, hot water will last less to be ready in any tap of the branch, as the main common pipe is already pre-heated. So, as long as the **Activator Module** and the **Bypass Module** wireless communication is perfect, using the **Activator** in a room will pre-heat the main pipe that serves the rest of the rooms where that branch leads hot water to.

• **How long will it take for WAISENSE Comfort to return the investment?**

This time depends on multiple variables: the water tariffs of the region, the number of users in the installation, the times hot water is used daily or the total investment made, among other factors.

On average, a family of four whose members only use hot water once in a day, at a cost of €2.527 per cubic meter of water, using **WAISENSE Comfort** would result in €127.07 savings a year. Considering this, the return of the investment will occur between the fifth or sixth year. In comparison, solar panels return the investing around the eleventh or twelfth year.

But the most promising feature of **WAISENSE Comfort** is not about the economic savings. In fact, the key argument relays on the over 50,280 litres (11,060 gallons) of drinking water that will be saved every year for that family. Besides the great contribution to a more sustainable world, the quality of life of the users will also improve vastly.

• **Does WAISENSE Comfort manipulate the gas installation?**

No, it does not. **WAISENSE Comfort** is completely independent from the gas installation. The only connections needed for the modules are to the plumbing and electrical installations.

• **What if I change the water heater or I make some other plumbing modifications?**

Any alteration of the plumbing system where a **WAISENSE Comfort** equipment has been successfully installed, may affect to the behaviour of the device, as well as to the rest of the taps or appliances using water. As soon as the changes are made, you need to check the adequate performance of **WAISENSE Comfort** again. If something does not work properly, you must follow the explained installation process as if the product was a new acquisition. At the end, please test again the operation of the cycle from every **Activator Module**.

• **Does WAISENSE Comfort boost the performance of my individual water heater?**

No, it does not. Even it could be a consequence of the working principles of **WAISENSE Comfort**, the device has not been designed to improve the performance of water heaters, but to avoid the wastage of water as explained.

• **Is WAISENSE Comfort compatible with lime removing systems?**

Perfectly compatible. In fact, attaching a lime removing system to the plumbing installation will increase the functioning lifecycle of any appliance using water, including **WAISENSE Comfort** modules.

• **Does WAISENSE Comfort incorporate any safety measures to protect the installation it is attached to?**

Of course, it does. The first one consists on the filters that are provided with the modules the connect to the plumbing installation, for avoiding lime scales and other little rocks to enter the modules. Another safety measure is a thermostat located inside the **Power/High Power Module**, that stops the power supply if it detects that the temperature of the module rises up to 70°C. This situation can occur, for example, if these modules are connected to the water lines after a water heater, and so, being fed with hot water.

• **How sensitive is the temperature sensor at the Bypass Module?**

This sensor is in charge of measure the temperature of the flow of water that passes through the module, sending a signal to the **Activator Module**. This signal will result in a blue, red or yellow light in the **Activator Module**. Besides its high resolution, you can still experience hot water when the **Activator Module** shows a yellow steady glow.

WAISENSE Comfort allows the user to select the temperature at which he/she wants the cycle to stop, from 25-45°C. If the recirculation process stops, for an instance, at 44°C (when the user selected 45°C), the **Bypass Module** will detect that the water temperature is below its established value, showing a yellow light in the **Activator Module**. However, a person is not able to measure the water temperature with bare hands, and so, even the water has not reached the desired value, it will sense hot.

• **Our house has a double-branch or dedicated return system for hot water. That is, there is an extra hot water pipe for the water return to the water heater or boiler. Is WAISENSE Comfort compatible with this installation too?**

Totally. Consider **WAISENSE Comfort** was designed precisely to create a recirculation cycle without the need for a secondary hot water pipe, using the cold

water line as return. In the case this dedicated return line exists, you would only need a special arrangement of the modules in the installation to use that return pipe for what it was meant to be instead of using the cold water pipe. As there are many types of recirculation plumbing installations using hot water return pipes, we recommend you to contact our technical service for detailed advice.

• **Does WAISENSE Comfort require any kind of maintenance?**

As any other appliance attached to the plumbing installation, **WAISENSE Comfort** is susceptible to the flow of water through the years. The main origin of damage in the devices connected to water pipes is the presence of lime and other small stones in the fluid. **WAISENSE Comfort** provides filters to be allocated in between the inlets of the modules and the connectors of the existing piping installation. It is recommended to add other external filters to improve the efficiency over time. Remember to remove them eventually to wash away all deposits, especially if we notice a pressure drop when using water or if the cycle lasts longer than initially.

• **What about the warranty?**

WAISENSE Comfort warranty covers the expenses of any damage that is original from the factory over the first two years after the purchase. Any other damage resulting from a faulty installation or misuse is not covered. All the details of the warranty are incorporated into the User's Manual, provided with each product.

• **Does the recirculation cycle always last exactly the same?**

Probably not. There are several variables to take into consideration. For example, the amount of time spent for the hot water to reach the **Bypass Module** will depend on the ambient temperature, the initial temperature of the pipes, the power of the heating unit, the amount of water to be recirculated, and so on. Moreover, even from the triggering moment, the cycle may not start right when the **Activator Module** is used. As an analogy to a WiFi router and other wireless signals emitters and receivers, **WAISENSE Comfort** communicates based on radiofrequency. All of these technologies are susceptible to interferences like electromagnetic fields, metallic objects and some other conditions. If we think about a WiFi router, we may have noticed how the signal has not always the same quality or range, maybe even losing connection for a couple of seconds. The same can happen to **WAISENSE Comfort**, but it is very rare. That is the reason why we included a yellow signal in the **Activator Module**, so you know if there is an issue with the wireless communication.

Generally, the user will not notice this condition, as **WAISENSE Comfort** will try to communicate eventually if the first attempt were not successful. That is why the blinking blue light in the **Activator Module** at the trigger of the cycle can last from 1 to 150 seconds, trying to communicate with the other modules.

• **Is WAISENSE Comfort designed only for dwellings?**

No, it is not. As we said before, **WAISENSE Comfort** benefits are useful for all consumers of hot water. If you are running a business using hot water, like a gym, a hostel or a hair salon, you will save water and money while your customers experience the comfort of smart hot water. Furthermore, including this technology into new building project is a way of differentiation to generate more interest on the construction promotion.

• **Does WAISENSE Comfort heat water itself?**

No, it does not. **WAISENSE Comfort** is not a water heater or a boiler. In fact, it needs an individual water heater to accomplish its mission to carry hot water to the taps.

• **OKAY, I am ready to experience the smart water living. What should I do next?**

First of all, we would like to thank you for sharing with us this commitment for a more sustainable future. For purchasing **WAISENSE Comfort**, enter our website (www.waisense.com) to identify your national distributor. Get in touch to receive technical and commercial advice, as well as the location of the nearest supplier. If you also want a professional installation service, ask for references to the national distributor.

• **Can I combine in the same installation the conventional Activator with the On-Battery Activator?**

You can combine them without problems. The mode of communication with one type of Activator or another is always the same with the rest of the modules that make up **WAISENSE Comfort** regardless of whether the supply of the Activator is to the mains or batteries.

“Now you are aware that there are innovative solutions to live a better life with less expense. Welcome to smart water living”

Go to www.waisense.com and locate your national product distributor for more information on **WAISENSE Comfort**, its applications and how to purchase it. If your country does not yet have a local distributor, contact us through the web form (www.waisense.com/contact/) and we will guide you on the best options to enjoy **WAISENSE** technology.



waisense comfort



**SPAIN
2020**